

# CleverCharge Home Installation Manual



CleverCharge  
By Danlaw

# INDEX

## **GETTING STARTED ..... 3**

Data Sheet ..... 3

Safety Instructions ..... 4

Package Contents ..... 6

Before Installing ..... 8

- Prepare the charger for installation
- Electrical Panel Breaker Type Requirements
- Configurable Breaker and Wire Sizing (Hardwired Variants)
- Location
- Positioning

## **INSTALLATION.....12**

NEMA Plug Installation  
(Model Number EV-111A OR EV-112A) ..... 12

- Existing NEMA Plug
- NEMA outlet installation
- Placement
- Installing the wallplate
- Mounting
- Removing the NEMA 14-50P cable (optional)

Hardwired Installation  
(Model Number EV-113A OR EV-114A)..... 17

- Determine wiring entry
- Placement
- Preparing your charger
- Installing the wallplate
- Mounting the charger
- Electrical wiring
- Rated current adjustment
- Closing the charger

Holster ..... 23

## **NEXT STEPS / SERVICE.....24**



Contains FCC ID: 2AC7Z-ESPC6WROOMU  
Contains IC ID: 21098-ESPC6WROOMU

# GETTING STARTED

# DATA SHEET

## General Specifications

Model	CleverCharge Home
Cable length	25ft
Color	Gloss White
Dimensions	305mm x 203mm x 81mm (without cable)
Charging protocol	SAE J1772, SAE J3400
Weight	18.73lb (with cable)
Operating temperature	-30°C to 50°C ambient
Storage temperature	-40°C to 70°C ambient
EMC compliance	FCC Part 15 Class B
Electrical safety	UL 2594, UL 2231
Energy Star Certified	Yes

## Electrical Specifications

Charging power (Hardwired)	48A/11.5 kW Max
Charging power (NEMA 14-50)	40A/9.6 kW Max
Circuit Breaker Type	NON-GFCI/Standard Circuit Breaker
Circuit and Breaker Amperage (NEMA 14-50)	50A
Circuit and Breaker Amperage (Hardwired)	*Configurable; Refer to Page 8
Voltage Rating	208 - 264 VAC (volts alternating current)
Connector type	SAE J1772 Type 1 or SAE J3400 (NACS)
Configurable current from	6A to rated current
Rated frequency	60Hz
Enclosure protection rating	Type 4
Power input connection	Plug connected (NEMA 14-50) or hardwired

## Model Number Structure

J1772 NEMA	EV-112A
J1772 Hardwired	EV-114A
NACS NEMA	EV-111A
NACS Hardwired	EV-113A



The CleverCharge EV Charger contains FCC ID: 2AC7Z-ESPC6WROOMU. This device complies with part 15 of the FCC Rules. Operation is subject to the following two conditions: (1) this device may not cause harmful interference, and (2) this device must accept any interference received, including interference that may cause undesired operation. This equipment complies with FCC RF radiation exposure limits set forth for an uncontrolled environment. This equipment should be installed and operated with a minimum distance of 20 centimeters between the radiator and your body.

Caution: Any changes or modifications not expressly approved by CleverCharge void the user's authority to operate the equipment.

\*Consult professional electrician for thorough assessment of circuit breaker and wiring size needs.

## GETTING STARTED

# SAFETY INSTRUCTIONS

SAVE THESE INSTRUCTIONS | INSTRUCTIONS PERTAINING TO RISK OF FIRE OR ELECTRICAL SHOCK.



**WARNING:** When using electric products, basic precautions should always be followed, including those below. This manual contains important instructions that cover the safe installation, operation, and maintenance of the unit.

- Read all instructions before installing and using your CleverCharge charger.
- Permanent (hardwired) connection of your charger and/or installation of electrical circuits, conduit, and NEMA receptacles must only be performed by a qualified electrician in accordance with all local electrical codes and ordinances. Unauthorized installation or modifications will void the manufacturer's warranty.
- This device should be supervised when using around children.
- Do not put fingers into the electric vehicle connector.
- Do not use your CleverCharge charger if the flexible power cord or EV cable is frayed, has broken insulation, or any other signs of damage.
- Do not use your CleverCharge charger if the enclosure or the EV connector is broken, cracked, open, or shows any other indication of damage.
- Do not operate your CleverCharge charger in temperatures outside its operating range of -22°F to 122°F (-30°C to 50°C).
- Do not open your charger in rain or other inclement weather.
- Do not open the front cover of your charger while it is connected to the power supply.
- Install your charger in a sufficiently ventilated location and avoid installation in areas with direct sunlight.
- Do not install your CleverCharge charger near flammable, explosive, or combustible materials.
- All documents can also be found online at [www.clevercharge.com](http://www.clevercharge.com).
- In case of flooding, do not operate your charger while it or your vehicle is submerged in water.
- If your charger was submerged in water due to flooding, have a qualified electrician inspect your charger prior to energizing or using your charger again.
- CleverCharge is intended for use with electric vehicles only. Specifically, it is intended only for electric vehicles not requiring ventilation during charging.
- CleverCharge is intended to be installed in stationary, grid-tied power systems. Do not use the CleverCharge EV Charger with back-up generators.
- Use 90°C wire, 6 AWG copper for setting 48A rating intended for hardwiring connection.

## Warning for CleverCharge Home AC Plug-in Products: Grounding Instructions

Your CleverCharge charger must be grounded. If it should malfunction or break down, grounding provides a path of least resistance for electric current to reduce the risk of electric shock. Your charger is equipped with a cord having an equipment grounding conductor and a grounding plug. The plug must be plugged into an appropriate receptacle that is properly installed and grounded in accordance with all local codes and ordinances.



**WARNING:** Improper connection of the equipment-grounding conductor may result in a risk of electric shock. Check with a qualified electrician or service person if you are in doubt as to whether the product is properly grounded. Do not modify the plug provided with the product. If it does not fit the receptacle, have a proper receptacle installed by a qualified electrician.

**WARNING:** Consult a qualified electrician to ensure that the installation meets local regulations.

## GETTING STARTED

# SAFETY INSTRUCTIONS

SAVE THESE INSTRUCTIONS | INSTRUCTIONS PERTAINING TO RISK OF FIRE OR ELECTRICAL SHOCK.

### Maintenance Instructions

- Your CleverCharge charger contains no user serviceable parts. Do not attempt to repair or service any other part of the unit yourself. If the unit requires servicing, please contact CleverCharge customer service.
- The installation, maintenance, and servicing of your CleverCharge charger must only be performed by qualified personnel in accordance with applicable local regulations.
- Protect your CleverCharge charger from any external impact.
- Take appropriate precautions with electronic medical implants.
- Disconnect the main service power to your charger before cleaning the unit.
- Do not use cleaning solvents to clean any part of your charger. Use a clean, dry cloth to remove accumulated dust and dirt.
- Under no circumstance should you over-tighten the connecting cable while it is connected to the vehicle.
- Ensure that the charging cable is positioned in such a way so that it will not be stepped on, tripped over, or subjected to damage or stress. Do not close your garage door on the charging cord.

### Moving and Storage Instructions

- Your CleverCharge charger should never be lifted or carried by the power supply cord or by the EV cable. Always lift or carry your charger by lifting up the charger's enclosure.
- The charger is only to be used for fixed installations and cannot be used as a portable device.
- Store your CleverCharge charger in a dry location, and within the storage temperature of -40°F to 158°F (-40°C to 70°C)

### FCC Note

This equipment has been tested and found to comply with the limits for a Class B digital device, pursuant to part 15 of the FCC Rules.

These limits are designed to provide reasonable protection against harmful interference in a residential installation.

This equipment generates, uses and can radiate radio frequency energy and, if not installed and used in accordance with the instructions, may cause harmful interference to radio communications. However, there is no guarantee that interference will not occur in a particular installation.

If this equipment does cause harmful interference to radio or television reception, which can be determined by turning the equipment off and on, the user is encouraged to try to correct the interference by one or more of the following measures:

- Reorient or relocate the receiving antenna of the affected radio or television.
- Increase the separation between the charger and any affected devices.
- Connect the charger to an outlet on a circuit different from the one to which any affected devices are connected.
- Consult the dealer or an experienced radio/TV technician for help.



## Contact Us

support@clevercharge.com

GETTING STARTED

# PACKAGE CONTENTS

YOUR NEW CLEVERCHARGE EV CHARGER CONTAINS THE FOLLOWING ITEMS. IF ANY OF THESE ITEMS ARE MISSING OR IF YOU BELIEVE THEY'VE BEEN DAMAGED, CALL SUPPORT IMMEDIATELY.

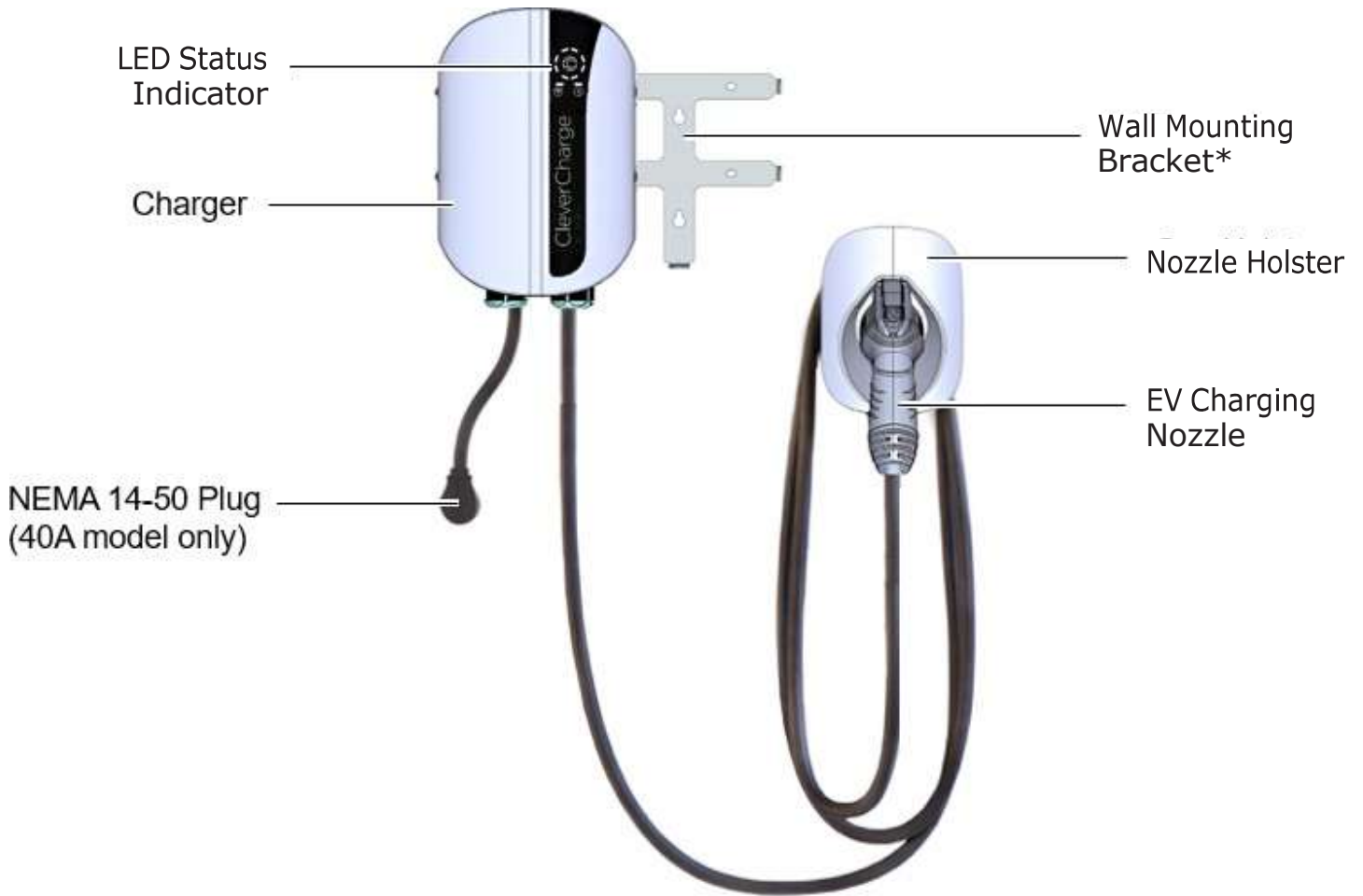

**\*NOTE:** The wall mounting bracket is pre-attached to the charger. Unscrew it before installation.

## GETTING STARTED

# PACKAGE CONTENTS

YOUR NEW CLEVERCHARGE EV CHARGER CONTAINS THE FOLLOWING ITEMS. IF ANY OF THESE ITEMS ARE MISSING OR IF YOU BELIEVE THEY'VE BEEN DAMAGED, CALL SUPPORT IMMEDIATELY.

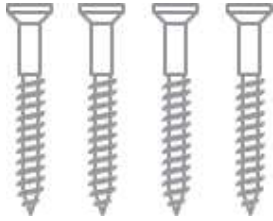

Four (4) Torx screws  
5x50mm  
(For installing wall  
mounting bracket)

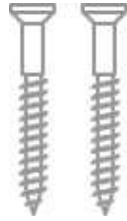

Two (2) Torx Screw  
5X50mm  
(For installing EV  
nozzle holster)

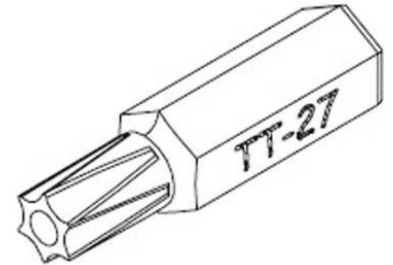

One (1) T-27 Torx  
Screw Bit

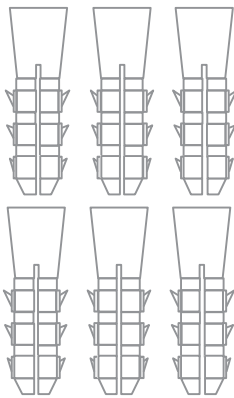

Six (6) drywall anchors



Four (4) M5X10mm  
Phillips screws  
(For wall mounting  
bracket)



Quick Start Guide

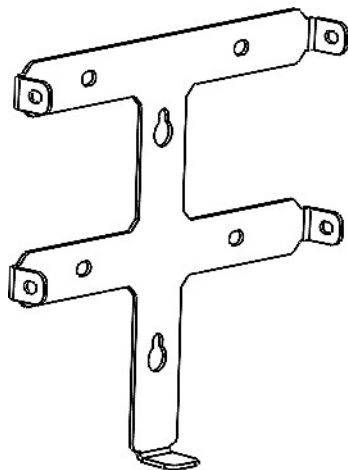

Wall mounting bracket\*

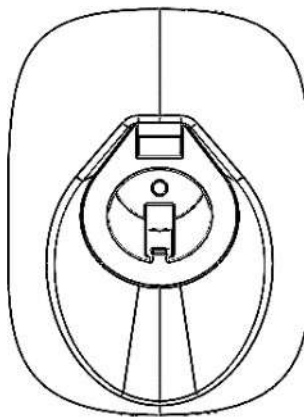

EV nozzle holster



CleverKey

**\*NOTE:** The wall mounting bracket is pre-attached to the charger. Unscrew it before installation.

## GETTING STARTED

# CONFIGURABLE BREAKER AND WIRE SIZING (HARDWIRED VARIANTS ONLY; MODEL NUMBER EV-113A OR EV-114A)

### **Recommended Installation:**

60A NON-GFCI Circuit Breaker and appropriately sized Wiring.

### **Optional Installation:**

Hardwired installations can use lower amperage breakers.

\*\*\*Please consult your local laws and electrical codes or consult a qualified electrician for details. Under no circumstances should a breaker larger than 60A be used with CleverCharge Home charger.

### **Optional Examples:**

#### **Scenario 1.**

An old HVAC air handler with a 40A electric heating element has been removed from the garage. The homeowner recently converted their home HVAC to use multiple newer mini split heat pumps in multiple rooms. This existing 40A circuit in the garage is repurposed for CleverCharge. Installers can connect CleverCharge to this 40A drop, and specify a circuit breaker size of 40A in the app during Out-of-Box setup with the CleverCharge phone app.

\*\*CleverCharge will limit vehicle charge current to no greater than 32A.

#### **Scenario 2.**

A water heater has been relocated, and an existing 240V 30A circuit remains in the garage. A decision has been made to install CleverCharge at this 30A circuit. During the Out-of-Box setup process with the CleverCharge app, a user or installer specifies CleverCharge is connected to a 30A breaker.

\*\*CleverCharge will work on this 30A circuit, limiting total vehicle charge current to no greater than 24A.

#### **Scenario 3.**

A customer wants to unlock the full 48A charging capability of CleverCharge, but no existing electrical circuit is available in the garage or outside the home. An electrician installs a new 60A drop circuit from the home electrical panel to the location where CleverCharge is to be installed. During the Out-of-Box setup process with the CleverCharge app, a user or installer specifies CleverCharge is connected to a 60A breaker.

\*\*CleverCharge will limit total vehicle charge current to no greater than 48A.

\*\* Per the National Electric Code (NEC), home electric panel circuit breaker and related wiring drops are sized to support continually running loads up to 80% of a circuit's rated capacity. CleverCharge Home Level 2 EV Charger will limit vehicle charging current to no greater than 80% of the defined size of the circuit breaker that CleverCharge is connected to in the home electrical panel.

\*\*\* All local electrical codes must be obeyed. Consult a qualified electrician for specific requirements in your location.

# PREPARE CHARGER FOR INSTALLATION

## WARNING:



- A NON-GFCI / Standard Circuit Breaker **MUST** be used in conjunction with your CleverCharge Level 2 EV Charger!
- CleverCharge contains an internal GFCI; it regularly tests its own GFCI functionality due to safety and compliance requirements.
- The self-test functionality of the CleverCharge GFCI can inadvertently cause a GFCI breaker supplying power to the CleverCharge electrical circuit to trip, resulting in lost power to the CleverCharge unit.
- To prevent false breaker trips, ensure a NON-GFCI circuit breaker is used in conjunction with your CleverCharge Level 2 EV Charger electrical circuit!

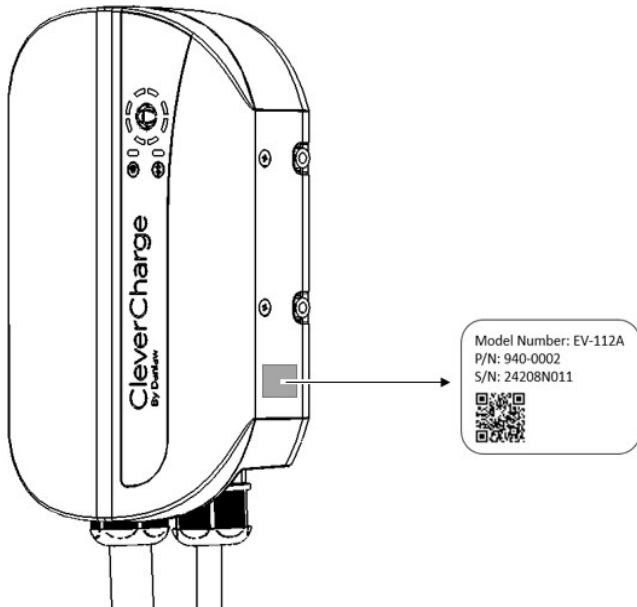

Before getting started, carefully lift the charger from the packaging, remove the cardboard covering the cables, and carefully unfasten the plastic cable ties on the EV cable bundle. Leave the cables in the box until needed to ensure they do not get damaged during installation.

## NOTE:

1. Check the product label to identify the model number of your charger. If the model number is not what you ordered contact support immediately.
2. Make note of the serial number (SN) and model number as you will need these to complete the registration of your charger.

## Tools Needed

Screwdriver, Stud finder, Drill, Pencil, Tape Measure, Level.

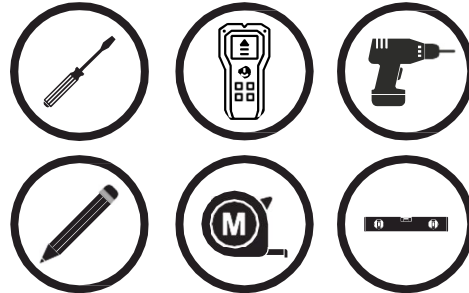

## Picking a location for Your Charger

For the placement of your charger, consider how you will normally park your car, the location of the vehicle's charge port, and the length of the charging cable (25 ft).

**NOTE:** You should always have enough slack in the charging cable so as not to apply tension to the cable or the cable connections.

For secure mounting, you will want to install your charger on a vertical wall stud or on a solid wall with appropriate mounting anchors.

In locating an area to install your charger, plan for adequate clearance from obstructions on the sides to access the side screws of the charger.

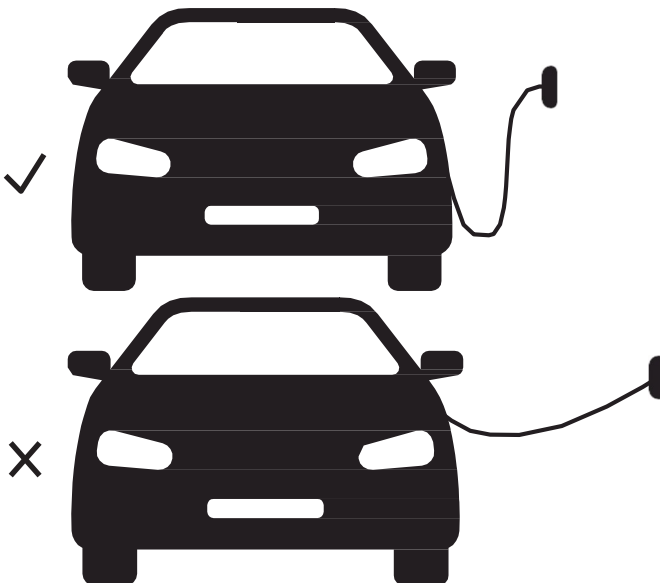

# PREPARE CHARGER FOR INSTALLATION



## Picking a location for Your Charger

### Inside Garage

#### Advantages

1. Faster charging in the winter. Vehicle batteries charge more slowly when cold.
2. Protect vehicle charging plug from dirt, rain and snow.
3. Avoid vandalism of EV charger and vehicle.

#### Disadvantages

1. You may not have a garage, or a garage that has room for a vehicle.
2. Charger is only accessible to vehicles inside of your garage. If you want to charge a friend, visitor or neighbor's vehicle, you must make room in your garage for their vehicle.

### Outside Garage

#### Advantages

1. You don't need a garage.

#### Disadvantages

1. Charger must be mounted outside which will be more expensive due to:
  - Additional mounting hardware and mechanical stands/adapters to mount either on a pole, or to siding, or brick/rock surface etc.
  - Longer electrical run from breaker box.
  - Drilling required through walls to outside area possible
2. Charger and vehicle are exposed to the elements
3. Slower charging in the winter
4. Potential vandalism of the charger
5. If exposed to direct sunlight in very hot climates on very hot days, may result in slower charging speed

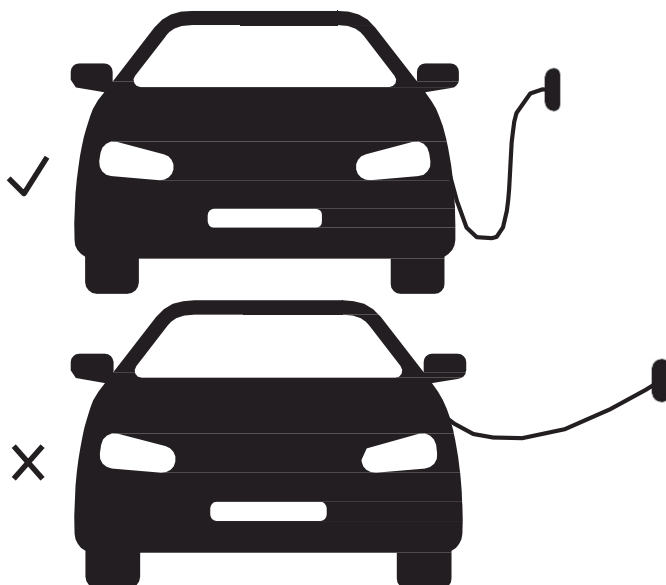

## GETTING STARTED

# BEFORE INSTALLING CLEVERCHARGE HOME

BEFORE INSTALLING YOUR CHARGER, BE SURE TO OBTAIN ANY REQUIRED PERMITS AND/OR APPROVALS IN ACCORDANCE WITH APPLICABLE CODES, REGULATIONS, AND ORDINANCES FOR ELECTRICAL INSTALLATIONS.



## Hardwired Version

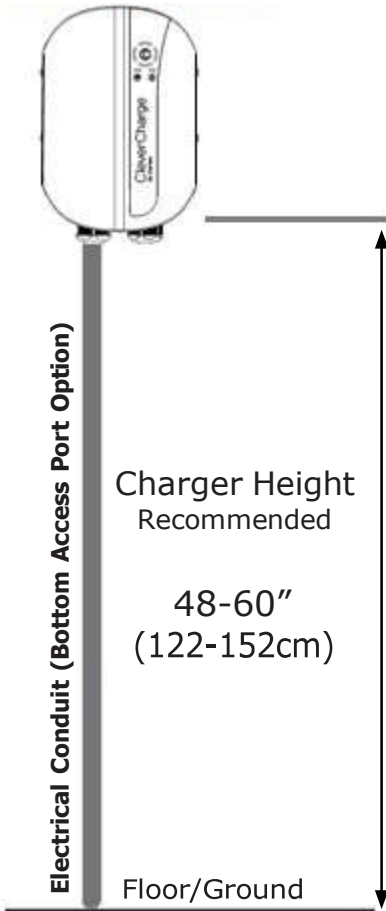

## Picking a Hardwired or NEMA plug installation

### Hardwired

#### Advantages

1. 20% Faster charging speeds possible (48A vs 40A).
2. Immune to rain/snow/dirt since the electrical connection is sealed (vs plugged in). Must be used for outside/outdoor installations.

#### Disadvantages

1. Higher electrician costs for installation (~ \$300-\$500 more).
2. Requires an electrician to remove charger, or to install a different charger.
3. Must be sold with the home (in most cases).

### Positioning Considerations

For hardwired installations, the wiring may use either the rear or bottom access ports in your charger. Be sure to note that the power supply wiring and conduit (if used) will need to be placed on the left side of your charger.

## GETTING STARTED

# BEFORE INSTALLING CLEVERCHARGE HOME

BEFORE INSTALLING YOUR CHARGER, BE SURE TO OBTAIN ANY REQUIRED PERMITS AND/OR APPROVALS IN ACCORDANCE WITH APPLICABLE CODES, REGULATIONS, AND ORDINANCES FOR ELECTRICAL INSTALLATIONS.



## NEMA 14-50 Plug-in Version

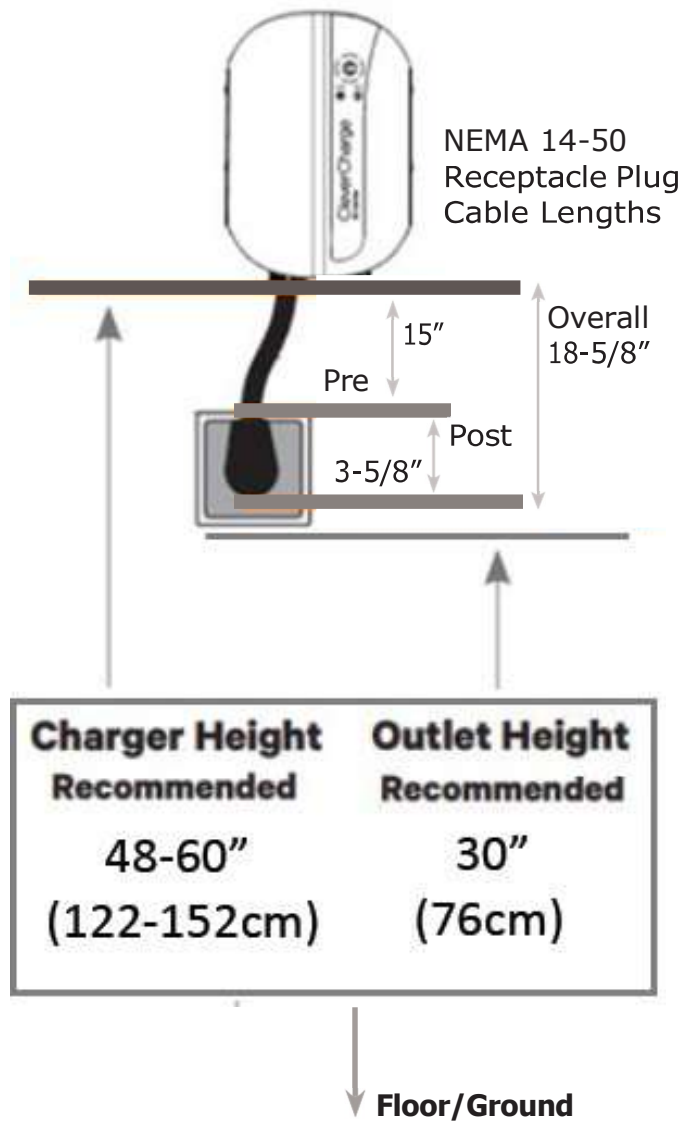

### NEMA Plug

#### Advantages

1. Can easily replace charger with another charger (any brand).
2. Can use the NEMA 14-50 plug for other purposes in the garage.
3. Lower electrician costs for installation.
4. Can be removed and taken with you if you sell your home.

#### Disadvantages

1. Slower charging speeds than hardwired (40A vs 48A).
2. Can not be used for outside installs.

### Positioning Considerations

With NEMA 14-50 Plug-in versions of CleverCharge, make sure to take into consideration the approximately ~18" (46cm) length of cable when position your charger in relation to your NEMA receptable.

We recommend a charger installation height of 48-60" (122-153cm). Also recommend installing your charger as shown in the diagram on the left. Note that the recommended installation height above the NEMA 14-50 outlet is approximately 18" (46cm), as measured from the bottom of your charger.

## INSTALLATION

# NEMA PLUG-IN INSTALLATION

REFER TO ONE OF THE CORRESPONDING SUB-SECTIONS BELOW FOR AN EXISTING NEMA OUTLET OR FOR INSTALLING A NEW NEMA OUTLET.

### WARNING:



- A NON-GFCI / Standard Circuit Breaker **MUST** be used in conjunction with your CleverCharge Level 2 EV Charger!
- CleverCharge contains an internal GFCI; it regularly tests its own GFCI functionality due to safety and compliance requirements.
- The self-test functionality of the CleverCharge GFCI can inadvertently cause a GFCI breaker supplying power to the CleverCharge electrical circuit to trip, resulting in lost power to the CleverCharge unit.
- To prevent false breaker trips, ensure a NON-GFCI circuit breaker is used in conjunction with your CleverCharge Level 2 EV Charger electrical circuit!

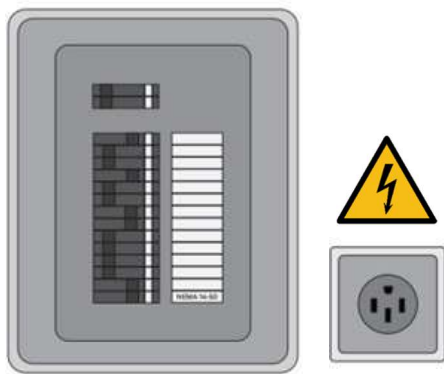

### Existing NEMA outlet

If you already have a NEMA outlet, ensure that:

1. It complies with local electrical codes.
2. It has a designated circuit breaker and electrical wiring that are dimensioned appropriately.
3. The NEMA 14-50 outlet **MUST** be EV rated or industrial rated.



Switch off the circuit breaker of the electrical outlet before installing your charger.



Instructions for electricians to install a NEMA outlet to be used with a CleverCharge EV charger.

### NEMA Outlet Installation

When installing a NEMA 14-50 outlet, mount the plug with the round ground hole in the UP position as shown on the left (assuming the charger will be mounted above the plug).

### Rated Current

EV Charger can supply a maximum charge of 40A to the EV.

Requires a dedicated 50A dual pole breaker.

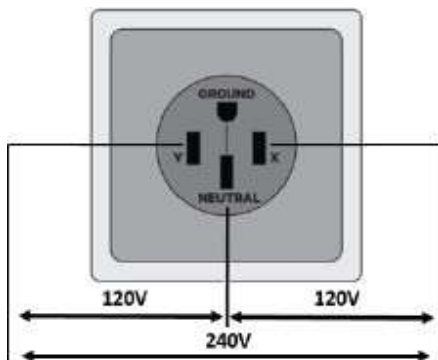

Dedicated Breaker	Charge Power @ 240 V	
50A	9.6kW	40A



**CAUTION:** To reduce the risk of fire, only connect your charger to a circuit with a branch circuit overcurrent protection of 125% of the selected max amperage setting of the device in accordance with ANSI/NFPA 70 (US) C22.2 NO 280 13 (Canada).



### **DANGER: Risk of fire or equipment damage:**

1. Use only EV-rated or industrial-rated NEMA 14-50 outlets
2. Do not allow any tension on the NEMA 14-50 cable when plugged in. Cable tension can lead to fires and electrical hazards.

## INSTALLATION

# NEMA PLUG-IN INSTALLATION

REFER TO ONE OF THE CORRESPONDING SUB-SECTIONS BELOW FOR AN EXISTING NEMA OUTLET OR FOR INSTALLING A NEW NEMA OUTLET.

### NEMA 14-50 with Cable Retractor Installation

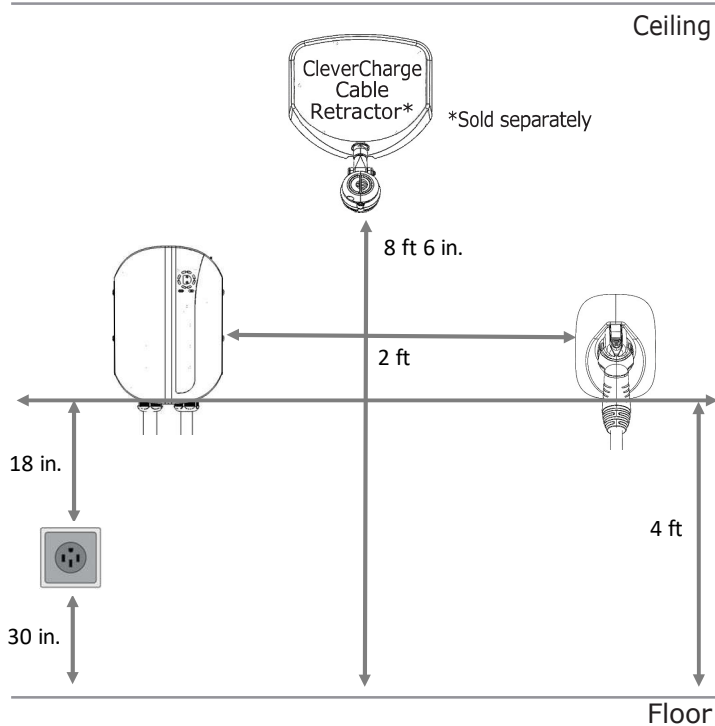

### NEMA 14-50 without Cable Retractor Installation

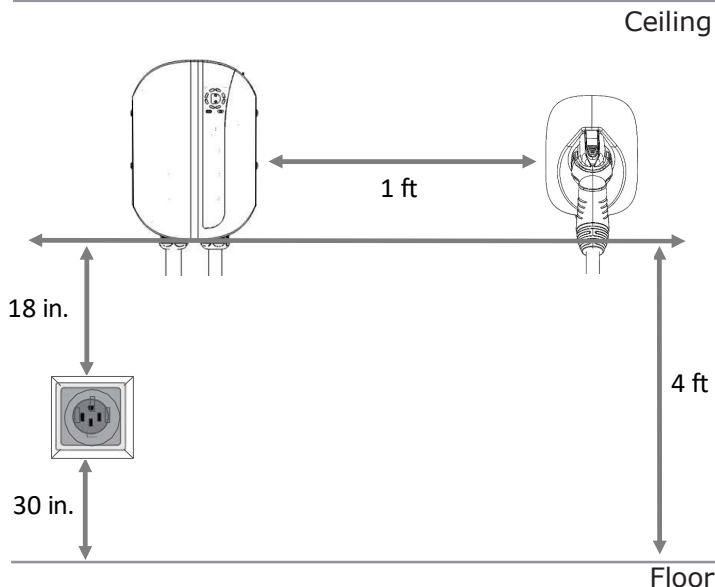

### Important Recommendations

1. Ensure you have the correct permits for this electrical installation.
2. Charger height is determined by the installed NEMA outlet height, so ensure that height information is provided to your electrician before the NEMA outlet is installed.
3. Remember that the NEMA outlet must be placed on the left side of the charger (as shown on Page 6 and 12), in order for the power supply cord to connect successfully to the NEMA outlet, and lay appropriately without unnecessary sideways/lateral torque on the outlet or cord.
4. NEMA outlet should be mounted ~30" above the floor, and the charger will be about 18" above this when installed (or around 4ft). If a different charger height is desired, then mount the NEMA outlet at 18" below the desired height of the bottom of the charger.
5. Keep in mind that the power supply cable length is approximately ~18" (46cm)
6. When installing our Automatic Cable Retractor at the recommended 8ft 6in height, position the wall mounted cable holster approximately 2ft away from the charger. This allows the cable to properly "drape" and hang properly above the floor, with ample room on both sides of the retractor when the charging cable is not in use.
7. When NOT installing our Automatic Cable Retractor, ensure there is at least 1ft of space between the wall mounted cable holster and the charger, to ensure sufficient space between the charger and holster to wrap/wind the charging cab on the wall mounted holster.
8. Ensure the electrical panel supports a 240V dedicated circuit with a new, dedicated two pole circuit breaker.
9. CAUTION: To reduce the risk of fire, connect only to a circuit with a branch circuit overcurrent protection of 50A in accordance with ANSI/NFPA 70 (US) C22.2 NO.280-13 (Canada).

## INSTALLATION

# NEMA PLUG-IN INSTALLATION

REFER TO ONE OF THE CORRESPONDING SUB-SECTIONS BELOW FOR AN EXISTING NEMA OUTLET OR FOR INSTALLING A NEW NEMA OUTLET.

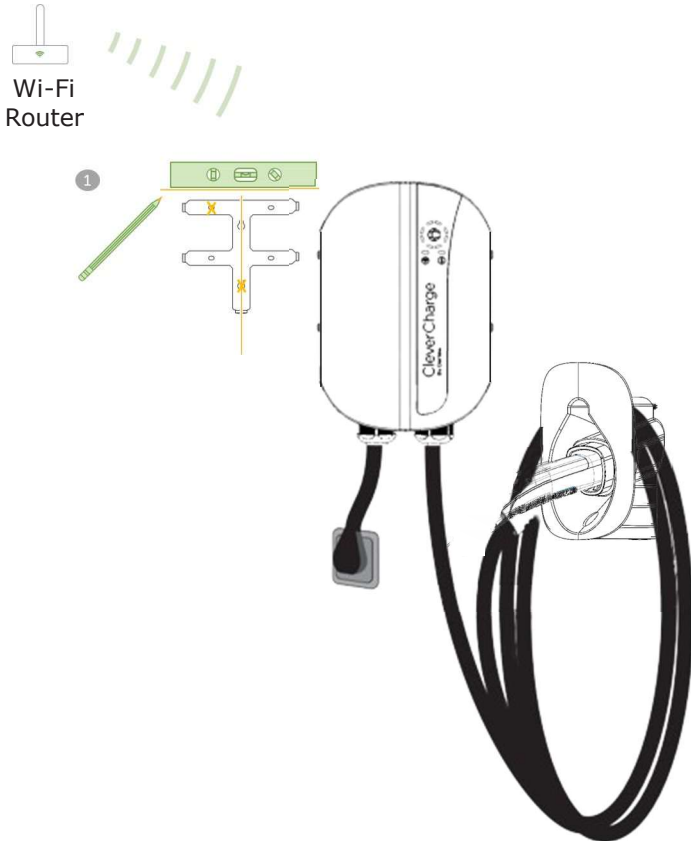

### Step 1: Placement

1. The charger should be placed within range of Wi-Fi signal and the NEMA outlet.
2. Locate the stud charger will be mounted to using a stud finder. Mark centerline of stud up and down the wall where charger will be mounted. This line will be used position the charger bracket on stud.
3. To precisely locate the charger's mounting position, switch your NEMA outlet circuit breaker to the OFF position (removing power to the outlet), then plug your charger into the outlet. Because the charger's power supply cable is thick and inflexible, it is advisable to position the charger and mark the desired mounting spot while power supply cable is connected to the power outlet. This helps you gauge and duplicate the real-world position of the charger, to ensure the mounting spot isn't placing undo stresses on the cable, plug, or NEMA outlet.
4. The charger is shipped with the wall mounting bracket attached to the charger. Leave it attached for this measurement.
5. Position the charger so that the marked stud center line is in the middle of the charger.
6. Use a level along the side of the charger to ensure the charger is positioned straight up and down (not tilted).
7. Mark the position of the left bracket on the wall.
8. Mark the position of the bottom of the bracket on the wall.
9. Unplug your charger from the NEMA plug and carefully place it back in the packaging box while you continue.

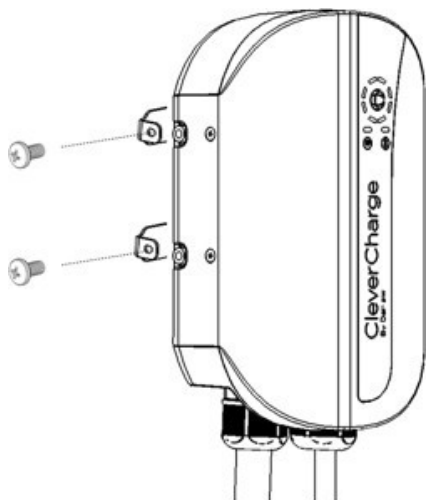

## INSTALLATION

# NEMA PLUG-IN INSTALLATION

REFER TO ONE OF THE CORRESPONDING SUB-SECTIONS BELOW FOR AN EXISTING NEMA OUTLET OR FOR INSTALLING A NEW NEMA OUTLET.

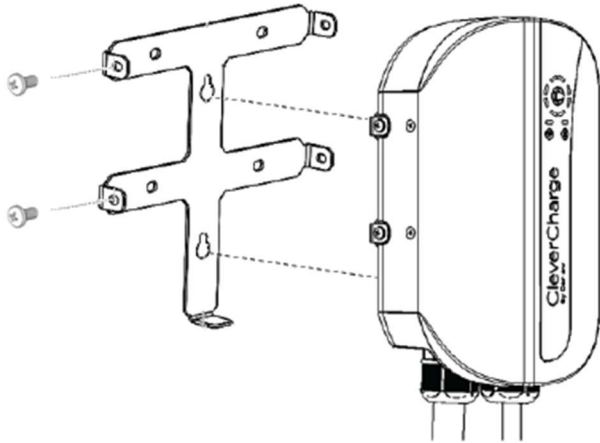

## Step 2: Installing the Wallplate

1. Remove wall mounting bracket from the back of the charger by removing the four (4) Phillips screws holding the bracket to the charger.
2. Position bracket to align with your top, center, and bottom wall markings you made in Step 1: Placement
3. Ensure the marked centerline aligns with the bracket's two center mounting holes.

### Stud Mounting (Maximum Stability and Strength)

1. Align and secure the two bracket center holes to a wall stud for maximum mounting stability.
2. Mark the top point of the bracket center teardrop holes in line with a wall stud. Drill 3/32" pilot holes approximately 2" deep into the wall and stud at the two marked center locations.
3. Partially screw in mounting screws into the stud, leaving a 1/4" gap between the screw head and the wall. Hang the mounting bracket on the screws, then tighten screws to completely secure the bracket.

### Drywall Mounting

**NOTE:** If fastening to stud is not achievable, or is only partly achievable off of bracket center, use all six bracket mounting holes (with provided drywall anchors for the holes required) for maximum securement to stud + drywall installation.

1. Mark the top point of bracket center teardrop holes on the drywall. If center holes are going into drywall, drill 1/4" pilot holes into drywall and press provided anchors into the holes.
2. Partially screw in the mounting screws into the two center drywall anchors, leaving a 1/4" gap between the screw head and the wall. Hang the mounting bracket on the screws. Press bracket against the wall and mark the centers of the other four bracket mounting holes.
3. Lift bracket off of the center screws, and drill holes into the four marked holes.
  - a. If all four remaining holes are going into drywall, drill 1/4" anchor pilot holes and firmly press anchors into them, then secure bracket to anchors with screws.
  - b. If any of the four remaining holes are going into a stud, drill stud pilot holes with 3/32" drill bit, and secure bracket to stud with screws.
4. Be sure to avoid overtightening screws in drywall anchors, which may cause anchors to spin.

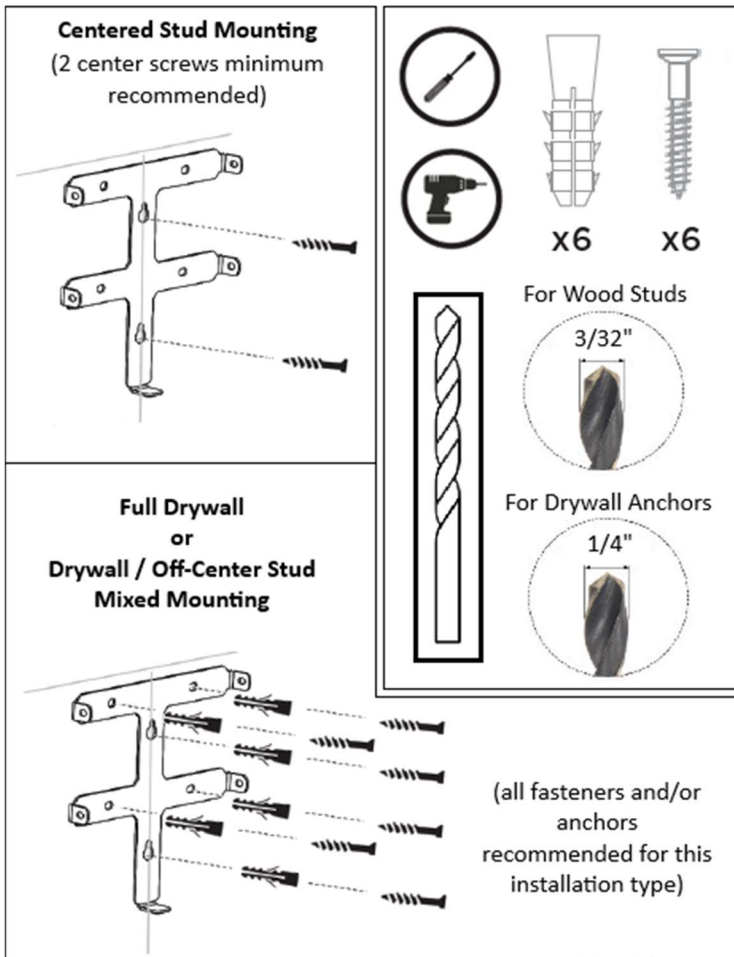

## INSTALLATION

# NEMA PLUG-IN INSTALLATION

REFER TO ONE OF THE CORRESPONDING SUB-SECTIONS BELOW FOR AN EXISTING NEMA OUTLET OR FOR INSTALLING A NEW NEMA OUTLET.

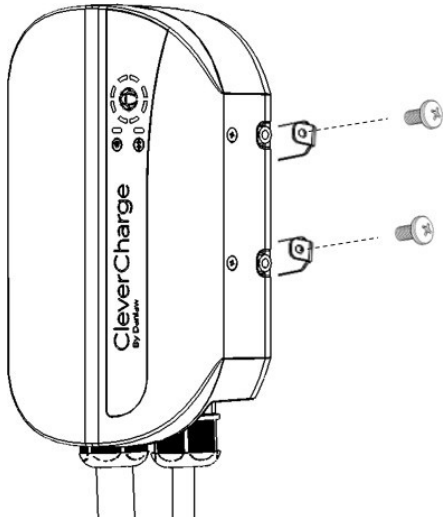
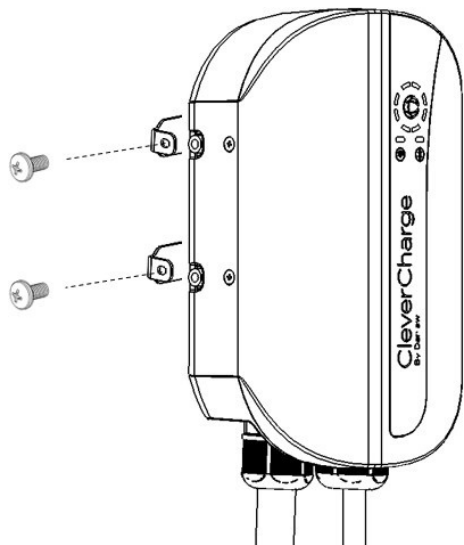

### Step 3: Mounting the Charger

1. With the wall bracket mounted, hang your charger from the wall bracket.
2. Hold the charger between the wall bracket screw hole posts, then align and install the four stainless steel side mounting screws (previously removed) through the bracket side holes into the charger threaded inserts.
3. Tighten the screws to secure charger to wall bracket. Do not overtighten.



## INSTALLATION

# HARDWIRED INSTALLATION

INSTALLATION OF YOUR CLEVERCHARGE CHARGER WITH A PERMANENT POWER SUPPLY.

### WARNING:



- A NON-GFCI / Standard Circuit Breaker **MUST** be used in conjunction with your CleverCharge Level 2 EV Charger!
- CleverCharge contains an internal GFCI; it regularly tests its own GFCI functionality due to safety and compliance requirements.
- The self-test functionality of the CleverCharge GFCI can inadvertently cause a GFCI breaker supplying power to the CleverCharge electrical circuit to trip, resulting in lost power to the CleverCharge unit.
- To prevent false breaker trips, ensure a NON-GFCI circuit breaker is used in conjunction with your CleverCharge Level 2 EV Charger electrical circuit!

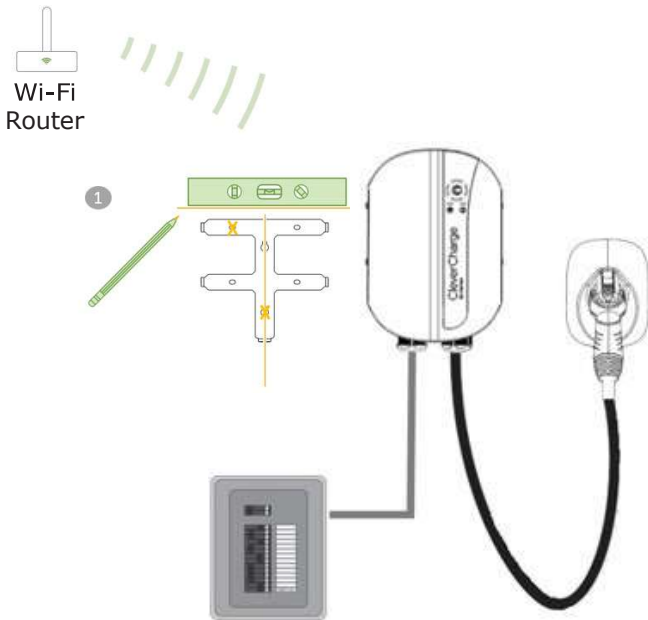

### Step 1: Placement

1. The charger should be placed within range of Wi-Fi signal.
2. Locate the stud the charger will be mounted to using a stud finder. Mark centerline of the stud up and down the wall in the area the charger will be mounted. This line will be used to exactly position the charger.
3. The charger is shipped with the wall mounting bracket attached to the charger. Leave it attached for this measurement.
4. Position the charger so that the marked stud center line is in the middle of the charger.
5. Use a level along the side of the charger to ensure the charger is positioned straight up and down (not tilted).
6. Mark the position of the left bracket on the wall.
7. Place the charger back in the packaging box while you continue.

### Hardwired with Cable Retractor Installation

Ceiling

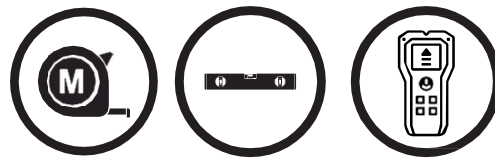
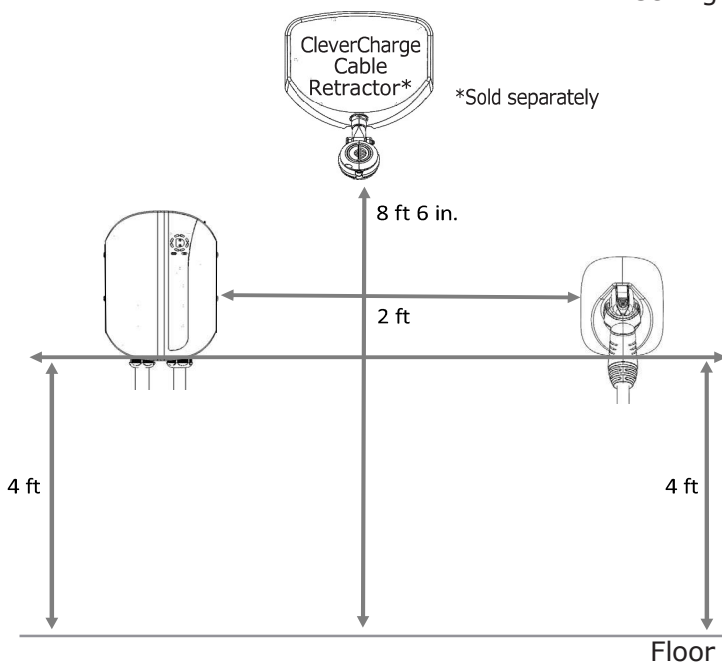

### Hardwired without Cable Retractor Installation

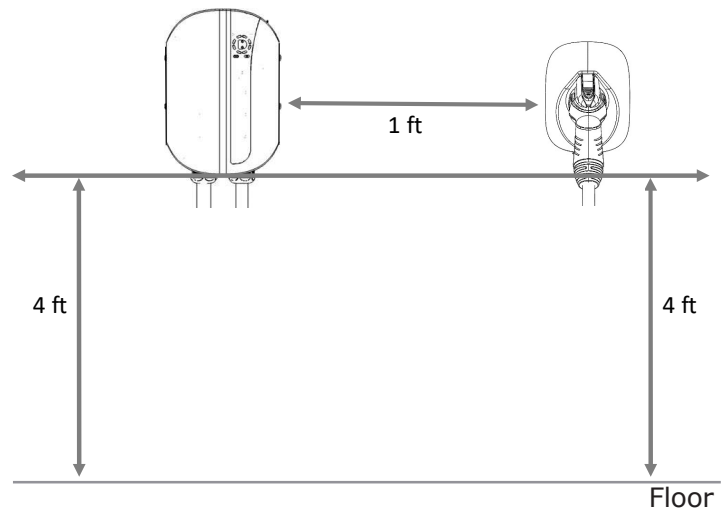

## INSTALLATION

# HARDWIRED INSTALLATION

INSTALLATION OF YOUR CLEVERCHARGE CHARGER WITH A PERMANENT POWER SUPPLY.

### Determine Wiring Entry

Before hardwired installation, determine which entry port you will be using for your power supply wiring or conduit. Your charger can be connected from either the rear or bottom entry ports. Choose the most appropriate connection based on the placement of your wiring or conduit.

Be sure to note that the power supply entry for either port will be on the left side of your charger. Ensure that you locate your charger so that the power supply wiring or conduit is accessible on the left side of your charger.

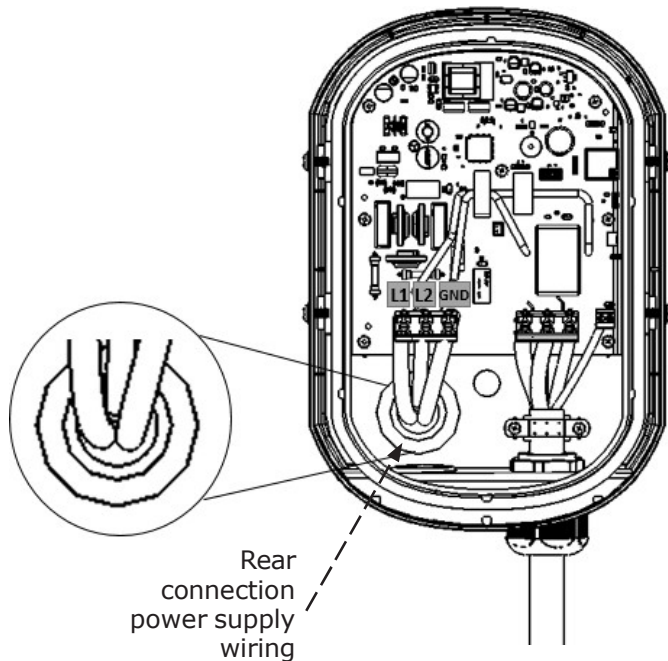
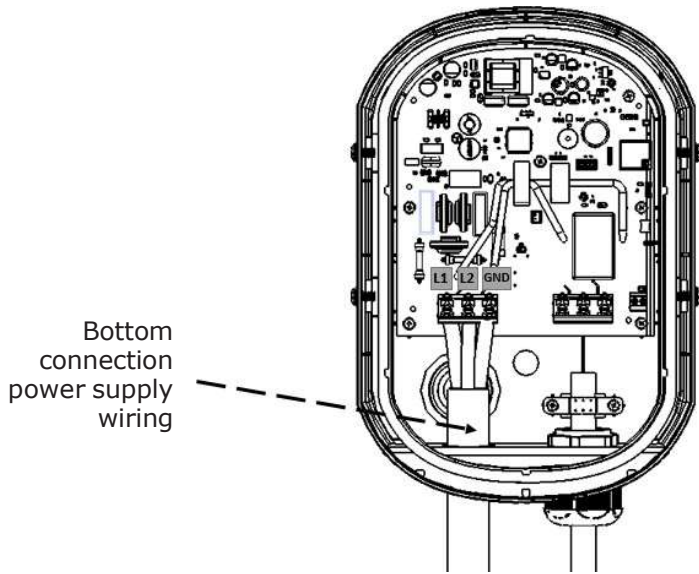

## INSTALLATION

# HARDWIRED INSTALLATION

INSTALLATION OF YOUR CLEVERCHARGE CHARGER WITH A PERMANENT POWER SUPPLY.

### Bottom Wiring Installation

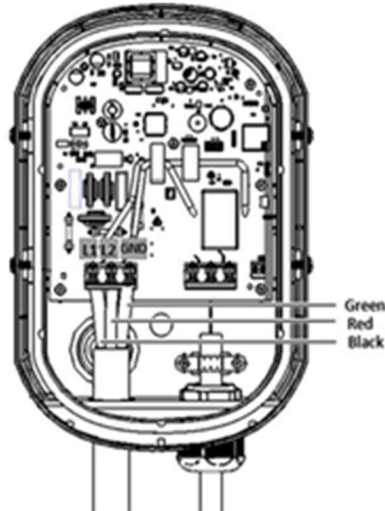

### Rated Current

EV Charger can supply a maximum of 48A to the EV. Requires a dedicated 60A dual pole breaker.

Dedicated Breaker Size	Charge Power @ 240 V	
60A	11.5kW	48A

### For Rear Wiring Installations

**Remove the rubber knock-out plug** to create an opening for your power supply wiring. Alternately, if you are using conduit for the rear attachment, the electrician has to remove the rubber knock-out plug and attach the conduit fitting to seal the unit.

### For Bottom Wiring Installations

**Remove the watertight cable gland from the bottom** to create an opening for your power supply wiring. The cable glands should be tightened to 70lbs-in (8Nm).

Alternately, if you are using conduit for the bottom attachment, the electrician must remove the cable gland and attach the conduit fitting to seal the unit.

### Rear Wiring Installation

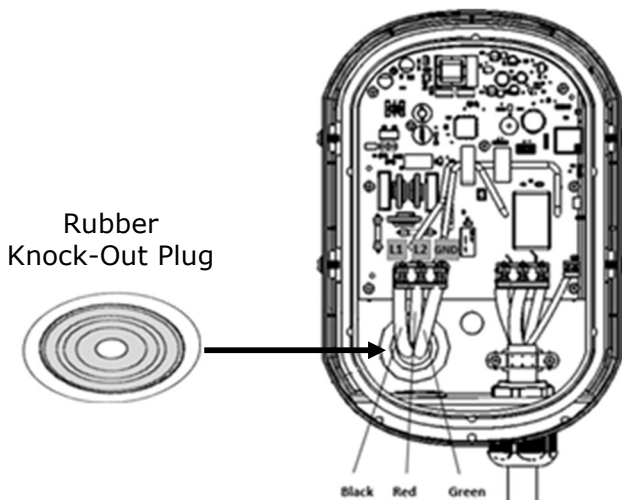

**NOTE:** The hardwired unit does not come with the NEMA 14-50A plug.

**CAUTION:** To reduce the risk of fire, only connect your charger to a circuit with a branch circuit overcurrent protection of 125% of the selected max amperage setting of the device in accordance with ANSI/NFPA 70 (US) C22.2 NO 280 13 (Canada).

### Electrical Wiring

1. For bottom wiring installation, feed the power supply wires through the bottom port with enough length to easily connect the wires to the terminals.
2. For rear wiring installation, feed the power supply wires through the rear port (after removing the rubber knock plug, if not using conduit) with enough length to easily connect the wires to the terminals.
3. Connect the electrical wires according to the diagram on the left.
4. Use copper conductors only with the wire size of 6 AWG (16mm<sup>2</sup>).
5. Strip 1/2" (12mm) of insulation off each wire, insert the wires per the diagram, and tighten each connector screw to **10.62lbs-in (1.2Nm)**.

**NOTE:** Ensure your electrical panel supports a 208/240V dedicated circuit with a new, dedicated two-pole circuit breaker rated for 60A. The voltage between the hot wires (L1 and L2) must be 208/240V.



## INSTALLATION

# HARDWIRED INSTALLATION

INSTALLATION OF YOUR CLEVERCHARGE CHARGER WITH A PERMANENT POWER SUPPLY.

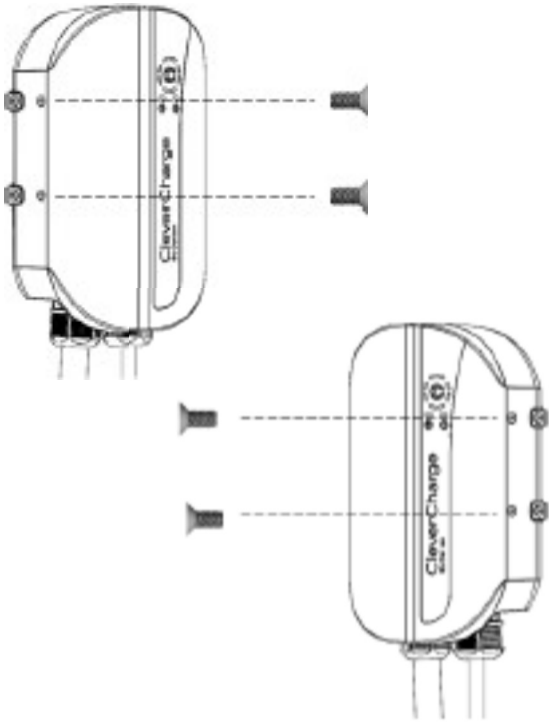

## Step 2: Removing the top cover and LED connector

1. Using a Phillips head screwdriver, carefully remove the four screws.
2. Position your fingers in the bottom groove and carefully lift the top cover from its base, ensuring even pressure. While lifting the cover from the bottom, be mindful of the LED connector that is attached to the top cover.
3. Carefully depress the small tab on the side of the connector while gently pulling the connector away from its socket.
4. After disconnecting the LED connector, set the top cover aside

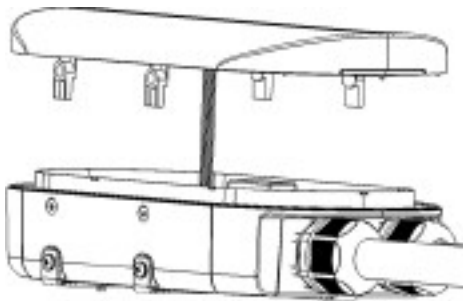

## Step 3: Installing the Wallplate

Refer to page 16

For rear wiring installation, draw the power supply wiring through the hole in the wall and then through the rear port of the charger before mounting the wallplate.

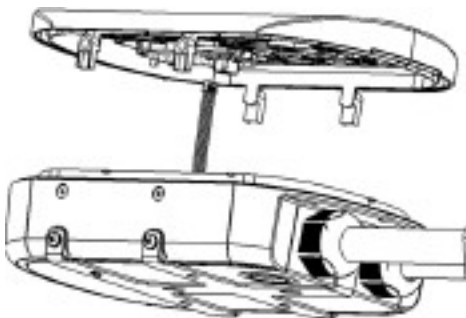

## INSTALLATION

# HARDWIRED INSTALLATION

INSTALLATION OF YOUR CLEVERCHARGE CHARGER WITH A PERMANENT POWER SUPPLY.

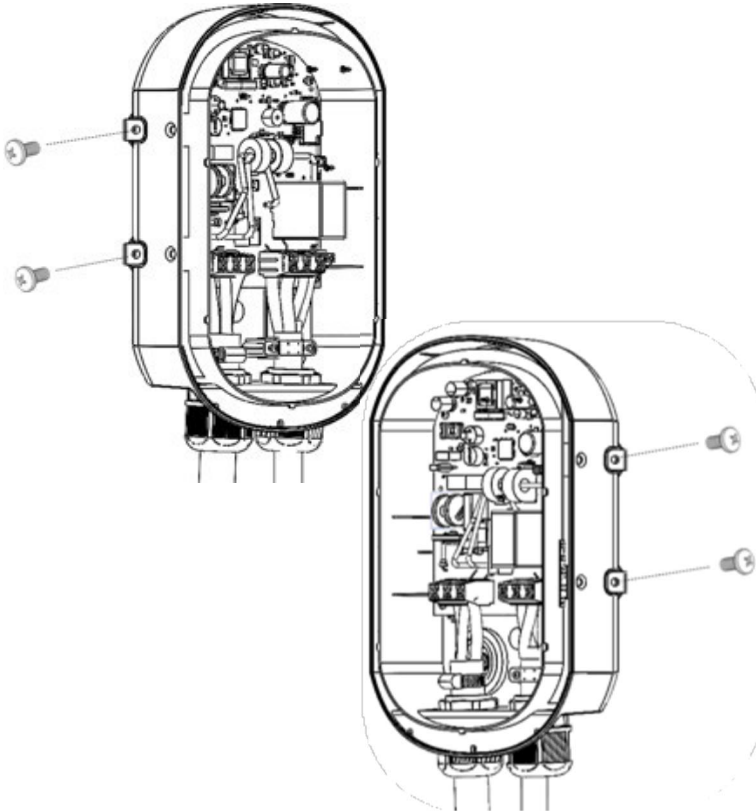

### Step 4: Mounting the charger

1. Carefully remove your charger from the packaging box and hang your charger from the top of the wallplate.
2. Hold the charger onto the mounting bracket while screwing the charger to the wall bracket using the four (4) stainless steel screws previously removed. Do not over tighten.

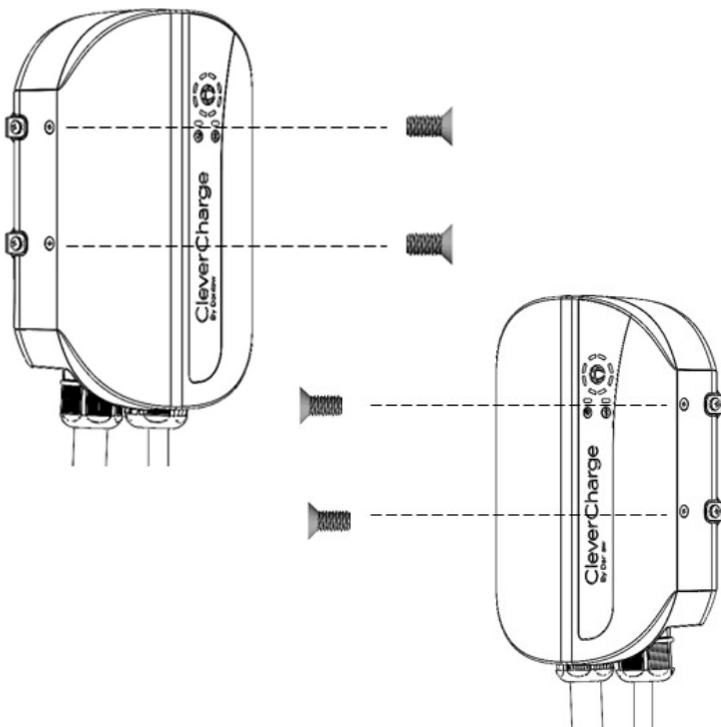
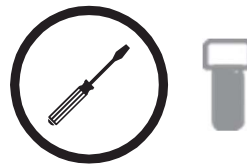

### Step 5: Closing the Charger

1. Carefully reattach the communications cable to your charger cover and close the cover of your charger.
2. Insert the four side screws to secure your charger cover. Do not over-tighten.



## INSTALLATION

# HOLSTER

APPLIES TO J1772 AND NACS PLUG.

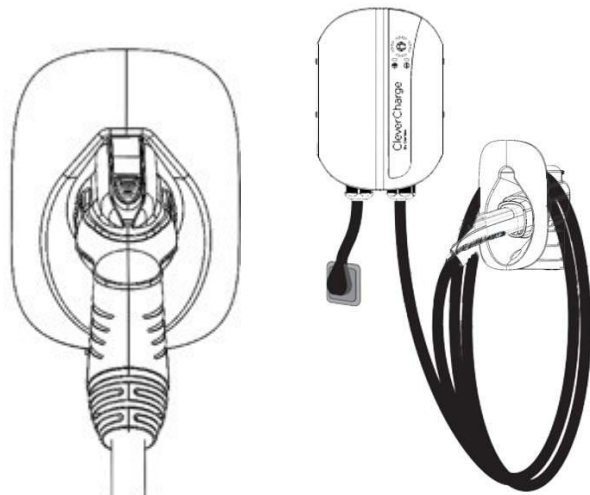
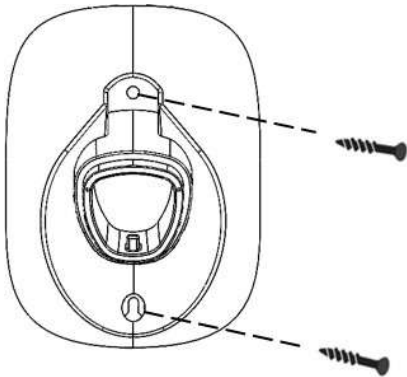
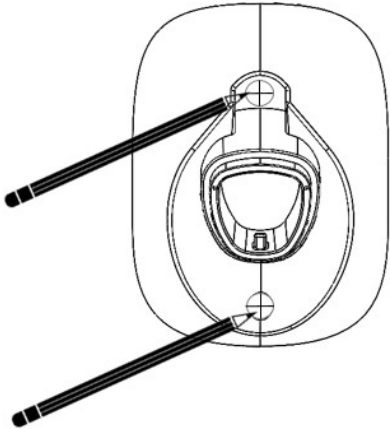

## Installing the Holster

The holster is used to store your EV connector when not in use. You may place the holster wherever it is most convenient, being sure that the location does not place any tension on the charging cable.

1. For a secure mounting, locate the holster on a vertical wall stud or similar solid wall.
2. Align the bottom of the holster with the bottom of the charger (if desired for aesthetics).
3. Mark the bottom hole and put the holster down.
4. Screw one screw into the stud leaving the head of the screw  $\sim 1/4$ " from the wall.
5. Put the holster on the bottom screw.
6. Fasten the holster securely with the two screws and Torx bit provided. Do not over-tighten.
7. Drape the charging cable around the holster and dock your EV connector in the holster.

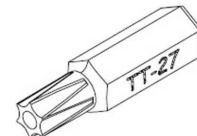

# NEXT STEPS / SERVICE

Need more assistance? Contact  
CleverCharge customer service.

For more information on CleverCharge please visit  
[www.clevercharge.com](http://www.clevercharge.com).

If the resolution requires support of our customer  
service department, please address your issues to  
[support@clevercharge.com](mailto:support@clevercharge.com). Emails will normally be  
answered within 24 hours.

Basic troubleshooting and online support is available  
at [www.clevercharge.com](http://www.clevercharge.com).

## Warranty Information

To review our Statement of Limited Warranty, visit:  
[www.clevercharge.com/statement-warranty-of-limited-warranty](http://www.clevercharge.com/statement-warranty-of-limited-warranty)

To review CleverCharge product warranty conditions and  
schedule information, visit:  
[www.clevercharge.com/e-commerce-policy](http://www.clevercharge.com/e-commerce-policy)

To inquire about warranty related repair or replacement,  
please contact CleverCharge customer service:  
Phone: **1-888-258-4286**  
Email: [support@clevercharge.com](mailto:support@clevercharge.com)



CleverCharge  
By Danlaw